



Undercounter ice maker up to 158 kg - Sprayer system

Hotel	████████████████████
Restaurant	████████████████████
Fast food	████████████████████
Bar	████████████████████
Disco	████████████████████
Fish market	████████████████████
Supermarket	████████████████████
Medical & SPA	████████████████████
Industry	████████████████████

► Position n°



► Features & Plus

- Compact and crystal cube
- AISI 304 SS Scotch Brite finish
- Tropical class +43°C
- Adjustable Stainless Steel feet
- Air or water cooling system
- Easy cleanable internal rounded surfaces
- HCFC-Free insulated storage
- RoHS Free
- Disappearing insulated door
- Electromechanical operation
- ON-OFF rocker switch
- Standard and special voltages



AISI 304 SS Scotch Brite finish



Adjustable Stainless Steel feet



Easy cleanable internal rounded surfaces



Disappearing insulated door

► Available ice cube size

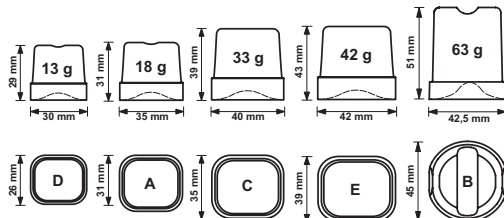

► Prod. 24h

Air temp.	Water temp.		kg	lbs
	10° C	50° F		
10° C	50° F	10° C	158	348
21° C	70° F	15° C	155	342

2 Years Warranty
subject to limitations

► Certifications available for this model





Ice Cube

CB 1565



Undercounter ice maker up to 158 kg - Sprayer system

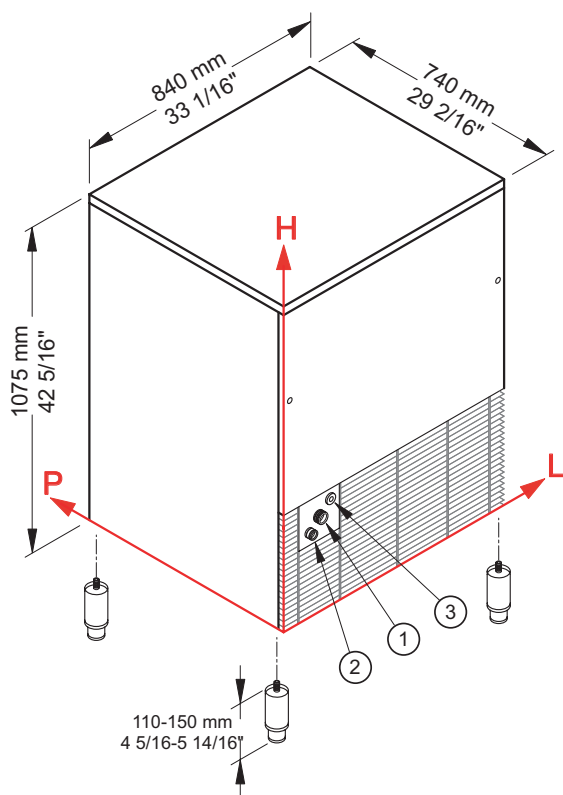

► Working conditions

- Location: **Indoor**

	Min	Max
Ambient temperature	+10° C / +50° F	+43° C / 110° F
Water temperature	+3° C / +37° F	+32° C / +90° F
Voltage	-10%	+10%
Water inlet pressure	1bar (14 psi)	6bar (84 psi)

► Performances

	Air temperature	Water temperature					
		10° C	50° F	15° C	60° F	21° C	70° F
	10° C	158 kg					
	50° F		348 lbs				
	21° C			155 kg			
	70° F				342 lbs		
	32° C					132 kg	
	90° F						291 lbs

► Connections

All measures are referred to the rear bottom-left corner (L-H-Ø)

- ① Water in.: 141 mm / 5 9/16" - 290 mm / 11 7/16" - 3/4" ② Water out.: 79 mm / 3 2/16" - 245 mm / 9 10/16" - 24 mm / 15/16"
 ③ Electrical connections: 186 mm / 7 5/16" - 326 mm / 12 13/16"

► Technical information

Production in 24h	155 kg / 342 lbs
Store capacity, up to	65 kg / 143 lbs
Cooling system	A - W
Kind of cube	A-18g, C-33g, D-13g, E-42g, B-63g
Refrigerant	R404A
Standard voltage	220-240 V ~ 50 Hz
Electrical consumption	1400 W
Fuse	16 A
Finish	AISI 304 stainless steel, scotch brite

Water consumption	A: 2,6 l/kg - 31,1 gal/100 lbs
	W: 13 l/kg - 155,8 gal/100 lbs
Sizes (L-P-H mm)	840 - 740 - 1075
(L-P-H in)	33 1/16 - 29 2/16 - 42 5/16
Sizes with pack (L-P-H mm)	880 - 785 - 1245
(L-P-H in)	34 10/16 - 30 14/16 - 49
Net weight	118 kg / 260 lbs
Gross weight	138 kg / 304 lbs

All the technical information must be considered at the following conditions:

- Sizes without feet
- Standard Cube (18 g)
- Ambient temperature +21° C
- Water temperature +15° C
- Electrical consumption at +43° C (standard voltage)

Models and specifications are subject to change without notice



BREMA ICE MAKERS SPA

Via dell'Industria 10,
20020 Villa Cortese (MI), Italy

tel. +39 0331 434811
fax +39 0331 433833

www.bremaice.it
info@bremaice.it

Bim + Data
download

Installation



We are Brema

